

## INDUSTRIAL PULLEY PULLER

"WHEEL MOUNT" PULLER DIMENSIONS

	Capacity	Max. Arm Width/ Work Diameter	Min. Arm Width	Foot/ Contact Length	Max. Arm Reach/ Work Depth	Cylinder Stroke	Height	Width	Arm Length	Weight	Hydraulic Pump	Volts
Model Number		"A" MAX	"B" MIN	C	D	E	F	G	H	---	---	---
PUL-8TON-PP	8 TON	22" (559mm)	3" (765mm)	2.25" (57mm)	21" (534mm)	5.5" (140mm)	44" (1118mm)	27" (686mm)	36" (915mm)	140lbs (64 kg)	Manual	---
PUL-20TON-PP	20 TON	30" (762mm)	5.5" (140mm)	3.5" (89mm)	40" (1016mm)	*5.0" (127mm)	49" (1245mm)	40" (1016mm)	48" (1220mm)	460lbs (209 kg)	Manual	---
PUL-20TON-ELPP	20 TON	30" (762mm)	5.5" (140mm)	3.5" (89mm)	40" (1016mm)	*5.0" (127mm)	49" (1245mm)	40" (1016mm)	48" (1220mm)	460lbs (209 kg)	10kpsi Electric	110V Standard 220V Available
PUL-60TON-PP	60 TON	35" (889mm)	3" (76mm)	4" (102mm)	45" (1143mm)	*6.0" (153mm)	54" (1372mm)	47" (1194mm)	60" (1524mm)	820lbs (372 kg)	Manual	---
PUL-60TON-ELPP	60 TON	35" (889mm)	3" (76mm)	4" (102mm)	45" (1143mm)	*6.0" (153mm)	54" (1372mm)	47" (1194mm)	60" (1524mm)	820lbs (372 kg)	10kpsi Electric	110V Standard 220V Available
PUL-100TON-PP	100 TON	41" (1042mm)	5" (127mm)	4" (102mm)	43" (1093mm)	*7.1" (180mm)	54" (1372mm)	53" (1346mm)	60" (1524mm)	1060lbs (481 kg)	10kpsi Electric	110V Standard 220V Available

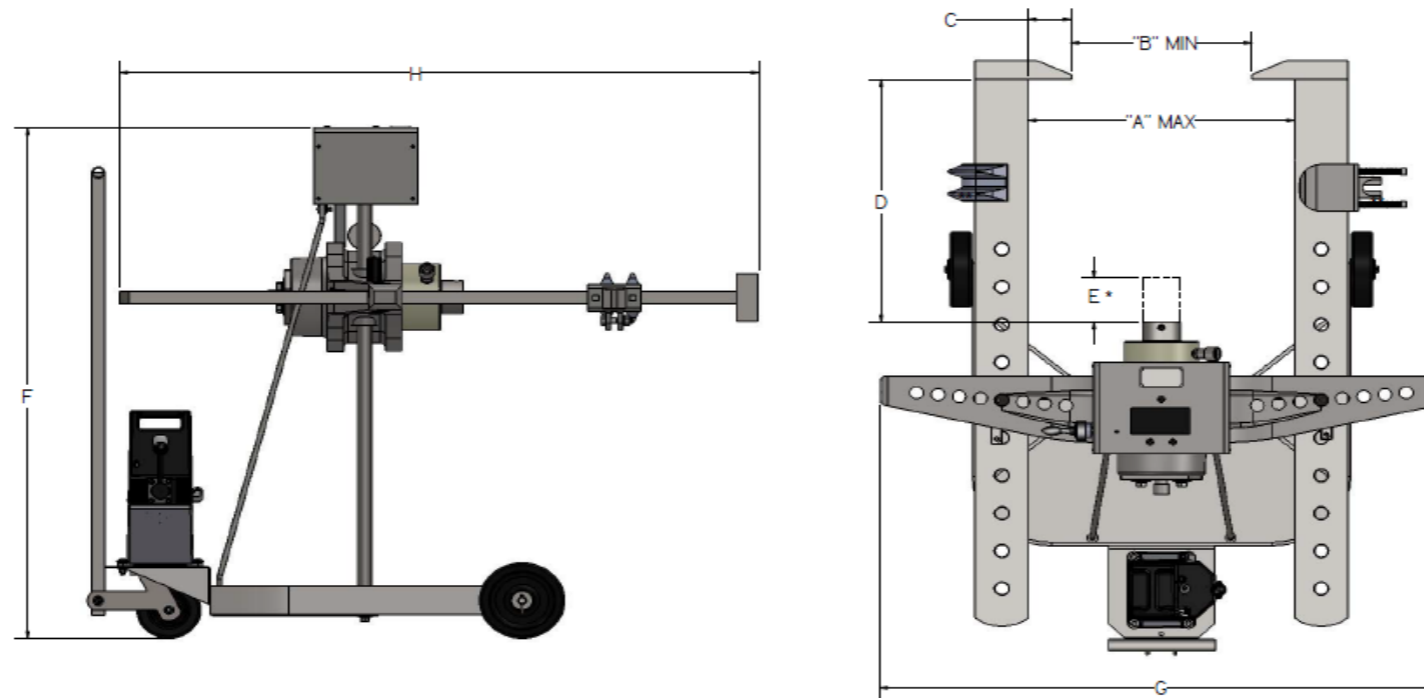

\* Ram extensions are included with puller to add to the ram stroke length

\*\* Quicklink chains are removed for illustration purposes

2670 NEWPORT RD NE  
IOWA CITY, IOWA 52240

PH: 1-888-443-2288  
FAX: 1-888-443-5088

EMAIL: SALES@PULLEYPULLER.COM  
WEBSITE: WWW.PULLEYPULLER.COM